

THERMOPHYSICAL PROPERTIES OF MOIST
DISPERSE MATERIALS IN A MAGNETIC FIELD

L. G. Chernaya, E. A. Raskina,
and L. V. Krasulina

UDC 536.2.081.7:541.182

Results are shown of an experimental study concerning the thermal conductivity and the thermal diffusivity of grade KSK-2 silica gel and of Glukhovets kaolin with various levels of moisture content in a constant nonuniform magnetic field varying from 0 to 6000 Oe.

Since various porous materials are widely heat-and-moisture treated by the electromagnetic method, it would be in interest to study the mechanism of heat and mass transfer processes in the presence of a magnetic field.

Earlier experiments [7] have shown that, in a magnetic field of an intensity varying from 2000 to 5000 Oe, the thermal conductivity λ and the thermal diffusivity a of moist quartz sand both increase during the transition from pendular to funicular moisture.

Knowing the thermophysical properties of moist capillary-porous materials will make it possible to analyze the various forms of moisture bond to the matrix material [3, 5, 8, 9]. For this reason, the authors have determined the thermophysical properties of moist disperse materials with various forms of moisture bond in a constant nonuniform magnetic field.

As the test specimens we selected two model porous materials in pure condition and ground to the following size fractions: Glukhovets kaolin $0.4 \text{ mm} > d \geq 0.05 \text{ mm}$ and silica gel $0.4 \text{ mm} > d \geq 0.06 \text{ mm}$.

Grade KSK-2 silica gel is a typical representative of capillary-porous materials [2] with various forms of moisture bond. Glukhovets kaolin [6] represents a colloidal capillary-porous material with predominantly adsorptive moisture bonded to the solid matrix within the hygroscopic range. The method of a continuous active heat source [4, 1], based on the characteristics of a transient temperature field, had been selected for determining the thermophysical properties of porous materials. This method ensures a short testing time and a short heating effect, it also yields all the thermophysical properties of a test specimen at the same time under the same conditions. This method is based on the solution to the equation of heat conduction for two semiinfinitely long rods [5] separated by a flat constant-power heat source. From the solution to that equation one determines the thermal activity b , the thermal conductivity λ , and the thermal diffusivity a according to the following formulas:

$$b = \frac{2q_1 \tau}{\sqrt{\pi} \Delta t_e}, \quad (1)$$

$$a = \frac{x^2}{4\tau \left[\arg \operatorname{ierfc} \left(0,5642 \frac{\Delta t_x}{\Delta t_e} \right) \right]^2}, \quad (2)$$

$$\lambda = b \sqrt{a}. \quad (3)$$

For determining the thermophysical properties, the test material was poured into a Plexiglass clamp (Fig. 1b) inside which was placed a flat heater element of 0.1 mm (diameter) manganin wire wound with a 1 mm pitch on varnished cloth. On top of the heater and the test material were placed two copper-constantan differential thermocouples, 5-6 mm apart and made of 0.1 mm (diameter) wire, with their cold junctions

Institute of Heat and Mass Transfer, Academy of Sciences of the BSSR, Minsk. Translated from *Inzhenerno-Fizicheskii Zhurnal*, Vol. 24, No. 5, pp. 876-880, May, 1973. Original article submitted November 16, 1971.

© 1975 Plenum Publishing Corporation, 227 West 17th Street, New York, N.Y. 10011. No part of this publication may be reproduced, stored in a retrieval system, or transmitted, in any form or by any means, electronic, mechanical, photocopying, microfilming, recording or otherwise, without written permission of the publisher. A copy of this article is available from the publisher for \$15.00.

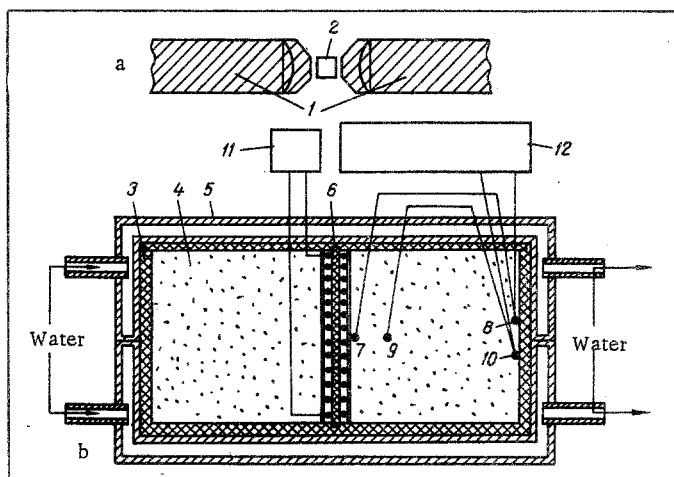

Fig. 1. Basic schematic diagram of the test apparatus for determining the thermophysical properties of disperse materials: (a) in a magnetic field, (b) without a magnetic field; 1) pole shoes of the electromagnet, 2) clamp containing the test material, 3) Plexiglass clamp, 4) test material, 5) thermostatic chambers, 6) heater, 7, 8, 9, 10) junctions of the thermocouples, 11) dc source, 12) model R 306 potentiometer.

at the cold end of the clamp at a constant temperature.

The Plexiglass clamp with the test material was placed inside a thermostatic chamber with double walls between which water circulated from a model TL-150 thermostat for maintaining a constant temperature. The heater was connected to a stabilized dc voltage supply, and the thermocouples were connected to a model R-306 potentiometer for temperature measurements. The thermocouple readings were recorded throughout the experiment and the readout time was noted with a two-hand stopwatch.

The specimens were moistened by holding the initially dry material in desiccators with air at different humidity levels. Prior to testing, these desiccators were placed together with the material in a dry-air thermostat at the test temperature of 25°C.

In this way, we prepared specimens of grade KSK-2 silica gel and Glukhovets kaolin with various levels of moisture content within the hygroscopic range. The material was held in desiccators until hygroscopic equilibrium with the ambient medium had been reached. The material was then made moist by direct contact with distilled water, continuous stirring, and holding for 48 h in the hermetically closed clamp so as to allow the moisture to become distributed uniformly over the entire specimen volume.

For testing in a magnetic field, the apparatus with a specimen was placed between flat-end conical pole shoes of an electromagnet (Fig. 1a).

The thermal conductivity λ and the thermal diffusivity a of the disperse materials in a constant non-uniform magnetic field of an intensity varying from 0 to 6000 Oe were determined within the range of moisture content from 0 to 15% in Glukhovets kaolin and from 0 to 140% in silica gel.

The test results are shown in Figs. 2 and 3. The trends of $\lambda(u)$ and $a(u)$ for the test materials can be explained by the different forms of bond between moisture and matrix.

The curves of thermophysical properties λ and a versus the moisture content (Fig. 2) for grade KSK-2 silica gel reveal a transition at two levels of moisture content u : about 9-10% and about 25-28%.

During the initial moistening period, when the water is strongly enough bonded to the solid phase, the thermophysical properties of a material are determined essentially by the solid phase and the interstitial air. For this reason, λ and a have the lowest values within the low range of moisture content u from 0 to 10%. Consequently, within this range of moisture content the bond to the matrix is adsorptive.

As the moisture content becomes higher, λ and a increase appreciably until a reaches its maximum

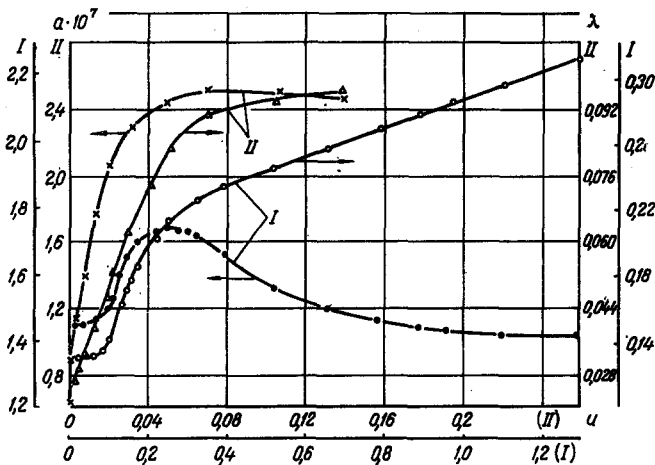

Fig. 2

Fig. 2. Thermal conductivity λ (W/m \cdot °C) and the thermal diffusivity a (m 2 /sec) of I) grade KSK-2 silica gel and II) Glukhovets kaolin, as functions of the moisture content u .

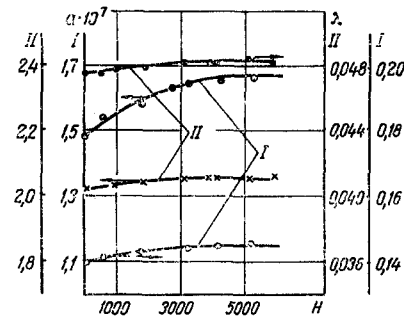

Fig. 3

Fig. 3. Thermal conductivity λ (W/m \cdot °C) and thermal diffusivity a (m 2 /sec) of I) grade KSK-2 silica gel and II) Glukhovets kaolin, as functions of the magnetic field intensity H (Oe): moisture content in silica gel $u = 9.6\%$ and in kaolin $u = 2\%$.

at $u \sim 25-28\%$. Within the $u \sim 10-28\%$ range the microcapillaries become filled up as the polymolecular films bonded to solid particles merge. The presence of water films at the intergranular boundaries improves the thermal contact: not only does the water join individual particles into clusters, but it also facilitates the transfer of heat from one particle to another.

As the moisture content u in the system increases above 28%, the thermal conductivity λ increases slower while the thermal diffusivity a decreases. This can be explained by the filling of medium-size pores in polyporous grade KSK-2 silica gel, when $u > 25-28\%$ and capillary menisci begin to form during capillary condensation of water vapor. The slower increase of λ and the decrease of a during a further increase in the moisture content u is, evidently, a result of a decreasing rate of heat transfer aided by mass transfer in adjoining less moist pores.

The curves of $\lambda = f(u)$ and $a = f(u)$ for Glukhovets kaolin reveal a predominantly homogeneous adsorptive moisture bond to the solid phase within the range of moisture content u from 0 to 2.7%.

The trend of these curves changes at $u > 2.7\%$, corresponding to a transition from adsorptive to capillary moisture.

In studying the thermophysical properties λ and a of Glukhovets kaolin and of silica gel with various levels of moisture content in a constant magnetic field, we have discovered an effect of the magnetic field on both λ and a of the selected materials, but only within the transition range from adsorptive to microcapillary moisture. According to the graphs (Fig. 3), the thermal conductivity λ and the thermal diffusivity a of Glukhovets kaolin with $u = 2\%$ moisture increase gradually and slightly as the magnetic field intensity H rises from about 2500 to 5500 Oe.

In the case of grade KSK-2 silica gel, both λ and a increase more appreciably when $u = 9.6\%$ and the magnetic field intensity H rises from 1000 to 5500 Oe.

The results of this experimental study lead to the conclusion that a magnetic field affects the thermal conductivity and the thermal diffusivity of a moist disperse material only when the moisture content is low and within the range of redistribution, i. e., within the range of transition from an adsorptive to a microcapillary bond.

The effect of a magnetic field on the thermophysical properties of the materials tested here within that definite range of moisture content can be interpreted as follows. A porous material moistens non-uniformly and during the initial stage of the process, when polymolecular water films have been formed, there still exist dry impurity particles of a solid which are in some way influenced by a magnetic field. As these particles move and reorient themselves in such a magnetic field, they can come in contact with

a polymolecular water film. Such a water film subsequently envelops these particles and forms additional thermal "bridges" between them. The thermal conductivity and the thermal diffusivity both increase then, which agrees with the results of our experimental study. Thus, a magnetic field affects the redistribution of moisture within the range of transition from a polymolecular adsorptive to a capillary bond.

NOTATION

λ	is the thermal conductivity;
a	is the thermal diffusivity;
b	is the coefficient of thermal activity;
u	is the specific moisture content in a material;
q	is the heater power;
x	is the distance between thermocouples in the specimen;
Δt_e	is the excess temperature of the heater above ambient;
Δt_x	is the excess temperature, above ambient, of the specimen at distance x from the heater;
τ	is the time.

LITERATURE CITED

1. A. B. Vershinskaya and L. N. Novichenok, *Inzh. Fiz. Zh.*, 9 (1960).
2. V. P. Dushchenko, M. S. Panchenko, S. F. D'yachenko, V. V. Bel'dii, and Kh. B. Baidzhanov, in: *Heat and Mass Transfer [in Russian]*, Izd. Naukova Dumka, Kiev (1968), Vol. 6, Part 1.
3. A. V. Lykov, *Desiccation Theory [in Russian]*, Izd. Énergiya, Moscow (1968).
4. A. V. Lykov, *Theory of Heat Conduction [in Russian]*, Izd. Vysshaya Shkola, Moscow (1967).
5. A. V. Lykov, *Theoretical Principles of Engineering Thermophysics [in Russian]*, Izd. Akad. Nauk BSSR, Minsk (1961).
6. F. D. Ovcharenko, *Hydrophilic Characteristics of Clay and Argillaceous Minerals [in Russian]*, Izd. Akad. Nauk UkrSSSR, Kiev (1961).
7. S. G. Romanovskii and E. A. Raskina, in: *Heat and Mass Transfer and the Thermophysical Properties of Materials [in Russian]*, Izd. Nauka i Tekhnika, Minsk (1969).
8. A. F. Chudnovskii, *Thermophysical Properties of Disperse Materials [in Russian]*, Fizmatgiz, Moscow (1962).
9. V. L. Shevel'kov, in: *Heat and Mass Transfer in Capillary-Porous Materials [in Russian]*, Gosénergoizdat, Moscow—Leningrad (1957).